



# FLO Ultra™

## Ordering Guide



# Table of Contents

1. Introduction .....	3
1.1 About FLO Ultra .....	3
1.2 Preparing the Quote .....	3
1.3 Parking Configuration .....	4
2. Pull-In Configuration .....	5
3. Pull-Through Configuration .....	5
4. Warranties and Services.....	6
4.1 Extended Parts-Only Warranty.....	6
4.2 Labor Warranty .....	7
4.3 FLO Performance Warranty.....	7
4.4 Required Services .....	8
5. Additional Components.....	9
5.1 Forklift Jig.....	9
6. Shipping Fees .....	9
7. Quote Examples.....	10
7.1 Pull-In Configuration – 5-Years Parts and Labor Warranty.....	10
7.2 Pull-Through Configuration – 5-Year FLO Performance Warranty .....	11
8. Copyright and Liability .....	12

# 1. Introduction

## 1.1 About FLO Ultra

The FLO Ultra™ DC fast charging station delivers the ultimate fast charging experience for every EV driver.

### Smart Design

The FLO Ultra fast charger has is easy to find and use, and is designed to get you back on the road quickly and safely.

### Brilliantly Simple

Two independent ports double the charging capacity, while our innovative FLO EZLift™ motorized cable management makes handling the cables effortless. The unique design favors visibility with high visible lighting canopy and state of charge indicators so you can spot the FLO Ultra at a distance.

### Built-to-Last

Station reliability and uptime are paramount when you are on the road. The modular architecture, rugged aluminum enclosure and easy serviceability are just a few of the ways FLO Ultra exemplifies fast charging done right.

## 1.2 Preparing the Quote

This Guide help you prepare a complete and accurate quote for the FLO Ultra and ensure the ordering process flows smoothly.

When preparing a quote, remember there are parts and services that are required and others that are optional.

Refer to the table below to ensure that your quote is complete.

Required Parts and Services	Optional Parts and Services
<ul style="list-style-type: none"><li>• FLO Ultra Charging Station Configuration</li><li>• Global Management Services (GMS)</li><li>• Annual Preventive Maintenance</li><li>• Annual Credit Card Fee</li><li>• One-Time Commissioning Fee</li><li>• Estimated Shipping Costs</li></ul>	<ul style="list-style-type: none"><li>• Extended Part-Only Warranty</li><li>• Labor Warranty</li><li>• FLO Performance Warranty</li><li>• Lifting Jig for forklift</li></ul>

## 1.3 Parking Configuration

The FLO Ultra offers flexible parking configuration options.

**The Pull-In parking configuration** is ideal for drivers to pull in or back in. The station will have the user interfaces and connectors on the same side.



**The Pull-Through parking configuration** is ideal for drivers to pull alongside the station. In this configuration, there is one interface and connector on the front and one on the back.



## 2. Pull-In Configuration



Part Number	Power Output	DC Input included	Cable Capacity	Connector Type
FL1DS1A1AA-FL-P18	320 kW	Yes	500 A liquid-cooled	CCS1

## 3. Pull-Through Configuration



Part Number	Power Output	DC Input included	Cable Capacity	Connector Type
FL1DS2A1AA-FL-P18	320 kW	Yes	500 A liquid-cooled	CCS1

## 4. Warranties and Services

Several types of warranties and Services are available with the FLO Ultra to ensure after-service care. Refer to the sections below for more information on the following types of warranties and services.

- Extended Parts-Only Warranty
- Labor Warranty
- FLO Performance Warranty
- Required Services
- Shipping Fees

### 4.1 Extended Parts-Only Warranty

The FLO Ultra Limited Warranty included with purchase is valid for a period of one (1) year. It is possible to purchase the Extended Part-Only Warranty for up to four additional years for a possible total coverage of five (5) years. Any Extended Warranty must be purchased at the time the product is purchased.

Part Number	Description
SPPW0000U1	FLO Ultra – Extended Part-Only Warranty - 1 year
SPPW0000U2	FLO Ultra – Extended Part-Only Warranty - 2 years
SPPW0000U3	FLO Ultra – Extended Part-Only Warranty - 3 years
SPPW0000U4	FLO Ultra – Extended Part-Only Warranty - 4 years

Refer to the *FLO Ultra™ Limited Warranty* document available only for more information.

## 4.2 Labor Warranty

FLO allows the purchase of a Labor Warranty in addition to the FLO Ultra Parts-Only Warranty to cover labor costs.

It is possible to purchase the Labor Warranty for up to five (5) years. The Extended Parts-Only Warranty must be purchased for the same coverage period. The Labor Warranty must be obtained at the time the product is purchased.

Part Number	Description
SPLW0000U1	FLO Ultra – Labor Warranty – 1 year
SPLW0000U2	FLO Ultra – Labor Warranty – 2 years
SPLW0000U3	FLO Ultra – Labor Warranty – 3 years
SPLW0000U4	FLO Ultra – Labor Warranty – 4 years
SPLW0000U5	FLO Ultra – Labor Warranty – 5 years

Refer to the *FLO Ultra™ Limited Warranty* document available only for more information.

## 4.3 FLO Performance Warranty

The FLO Performance Warranty offers the ease of obtaining one warranty that has the coverage of the Extended Parts-Only Warranty, the Labor Warranty and much more. Refer to the *FLO Performance Warranty* brochure available online for more information.

The FLO Performance Warranty includes:

- Guaranteed >98% uptime
- Preventative maintenance 1 x year
- Parts Warranty
- Labor Warranty (2 hours of travel time included)
- Labor covered to repair vandalism and automobile accidents
- Service Level Agreement (SLA) 1-business day
- Priority commissioning
- Priority station monitoring
- Customized quarterly reports



It is possible to purchase the FLO Performance Warranty for up to five (5) years. The FLO Performance Warranty must be obtained at the time the product is purchased.

Part Number	Description
DCWP0000U1	FLO Ultra – FLO Performance Warranty – 1 year
DCWP0000U2	FLO Ultra – FLO Performance Warranty – 2 years
DCWP0000U3	FLO Ultra – FLO Performance Warranty – 3 years
DCWP0000U4	FLO Ultra – FLO Performance Warranty – 4 years
DCWP0000U5	FLO Ultra – FLO Performance Warranty – 5 years

## 4.4 Required Services

The following services are required with the purchase of the FLO Ultra station. The FLO Global Management Service and Annual Credit Card Fee per Station must be renewed annually and can be paid in advance for up to a total of five years.

A minimum of one Preventive Maintenance per year is required for the duration of the purchased Parts-Only Warranty. Additional Preventive Maintenance may be required. Refer to the *FLO Ultra™ Limited Warranty* document available online for more information.

Part Number	Description
SPG30000U0	FLO Ultra – Global Management Service
SPPD0000U1	FLO Ultra – Annual Global Credit Card Fee per Station
SPMP0000U1	FLO Ultra – Preventive Maintenance (travel included)
SPCF0000U1V	FLO Ultra – Commissioning Fee per Station



## 5. Additional Components

This section contains additional and optional components that may be added to your order.

### 5.1 Forklift Jig

The following component must be added to your order if you are using a forklift to position the FLO Ultra on the mounting pad.

Part Number	Description
FLLT000001	FLO Ultra – Lifting Jig for forklift

**NOTE:** The Lifting Jig can be re-used for multiple installations. Refer to the Lifting section of the *FLO Ultra™ Installation Guide* for more information.

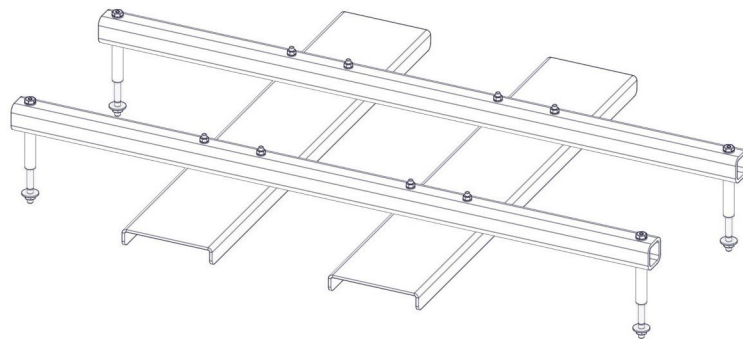

## 6. Shipping Fees

FLO offers shipping services through its transportation partners and can provide Shipping Fees based on location. Customers also can arrange shipping with their own transportation partners for their products.

Part Number	Description
FESH0001	Shipping Fees

## 7. Quote Examples

The following sections illustrate quote examples for a FLO Ultra based on different warranty options for 5 years.

### 7.1 Pull-In Configuration – 5-Years Parts and Labor Warranty

The table below shows an example of a FLO Ultra Pull-In configuration, with a DC input, a 500 A liquid-cooled cable and a 5-year warranty on parts and labor, with forklift-aided installation.

Part Number	Description	Quantity
FL1DS1A1AA-FL-P18	FLO Ultra 320 kW charging station, DC input, (2) 500 A liquid-cooled cables with CCS1 connectors	1
FLLT000001	FLO Ultra - Lifting Jig for forklift	1
SPPW0000U4	FLO Ultra - Extended Parts-Only Warranty - 4 years	1
SPLW0000U5	FLO Ultra - FLO Labor Warranty - 5 years	1
SPMP0000U1	FLO Ultra - Preventive Maintenance	5
SPG30000U0	FLO Ultra - Global Management Service	5
SPPD0000U1	FLO Ultra - Credit Card Annual Fee per station	5
SPCF0000U1	FLO Ultra - Commissioning Fee per Station	1
FESH0001	Shipping Fees	1

## 7.2 Pull-Through Configuration – 5-Year FLO Performance Warranty

The table below shows an example of a FLO Ultra Pull-Through configuration, with a DC input, a 500 A liquid-cooled cable and a 5-year FLO Performance Warranty.

Part Number	Description	Quantity
FL1DS2A1AA-FL-P18	FLO Ultra 320 kW charging station, DC input, (2) 500 A liquid-cooled cables with CCS1 connectors	1
DCWP0000U5	FLO Ultra - FLO Performance Warranty - 5 years	1
SPG30000U0	FLO Ultra - Global Management Service	5
SPPD0000U1	FLO Ultra - Credit Card Annual Fee per station	5
SPCF0000U1	FLO Ultra - Commissioning Fee per Station	1
FESH0001	Shipping Fees	1

## 8. Copyright and Liability

Document Name: FLO\_FLO Ultra\_Ordering Guide\_V11.0\_2025-03-19\_CA\_US\_EN  
Document ID: PRFM0104

FLO CA: © 2025 Services FLO Inc., All rights reserved. FLO, the FLO logo, FLO Ultra are trademarks of Services FLO Inc.

FLO US: © 2025 FLO Services USA Inc. dba FLO Charging Solutions USA Inc. in California, All rights reserved. FLO, the FLO logo, and FLO Ultra are trademarks of Services FLO Inc. used under license by FLO Services USA Inc.

All regions: This document is provided as a general instruction guide. All pictures shown are for illustration purposes only. Actual stations may vary in size or due to product enhancements, in which case additional steps may be required. AddÉnergie Technologies Inc. (dba FLO) and its subsidiaries (“FLO”) reserve the right to alter this document and any product offerings and specifications at any time without notice and FLO does not guarantee that that this version of the document is current. It is your responsibility to comply with all applicable laws, including those related to accessibility, zoning, and to exercise due diligence when conducting an installation or using this product. Careless installation or use may result in injury or product damage. To fullest extent permitted by applicable laws, FLO disclaims any liability for personal injury or property damage resulting from the installation or use of this product.



Learn more  
info@flo.com  
1 (855) 543-8356  
flo.com

Designed and manufactured  
by AddÉnergie Technologies Inc. d/b/a FLO.